

THIS INFORMATION IS CONFIDENTIAL AND IS DISCLOSED TO YOU ON CONDITION THAT NO FURTHER DISCLOSURE IS MADE BY YOU TO OTHER THAN PEXON PERSONNEL WITHOUT WRITTEN AUTHORIZATION FROM PEXON LTD.

DWG NO.  
100023-2

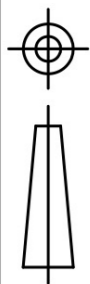

USED ON  
-

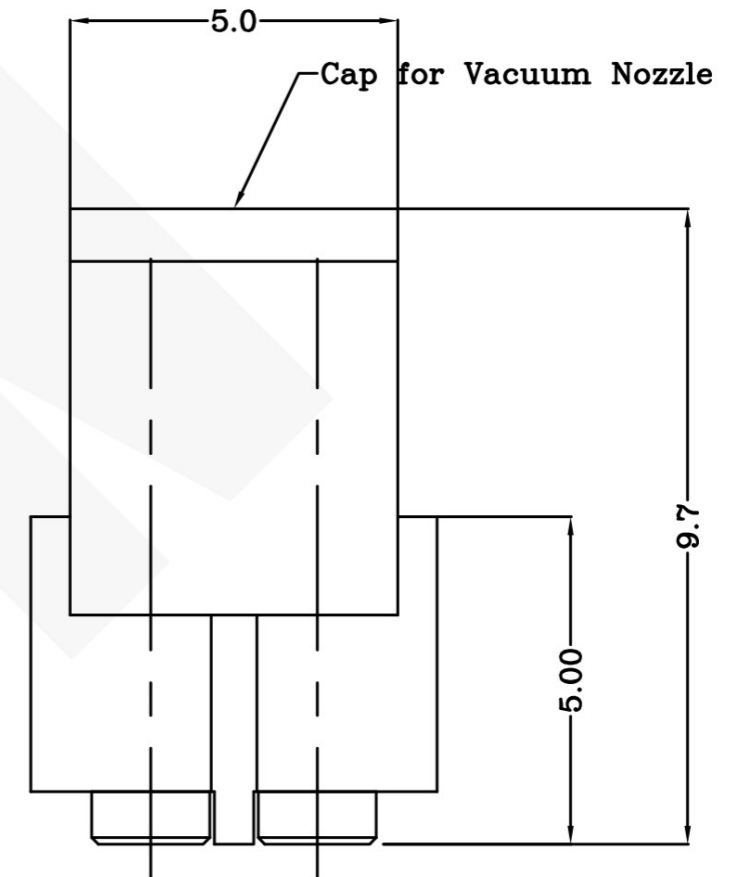
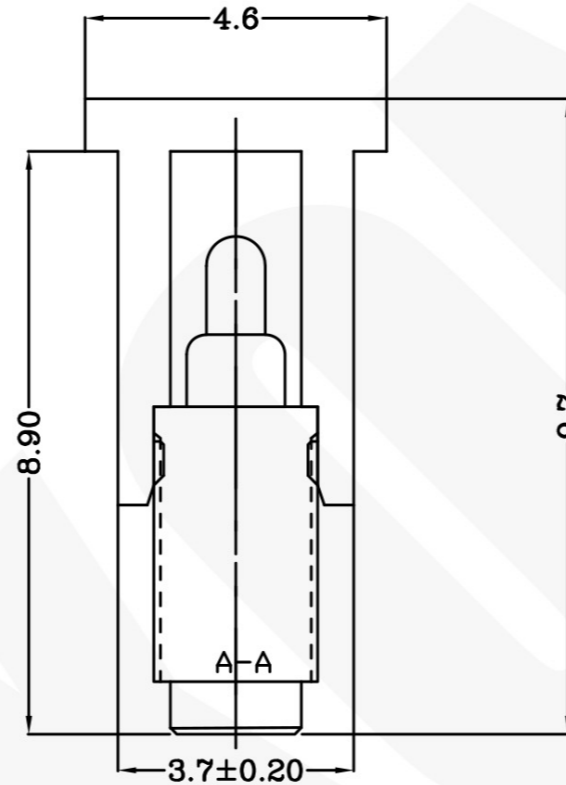
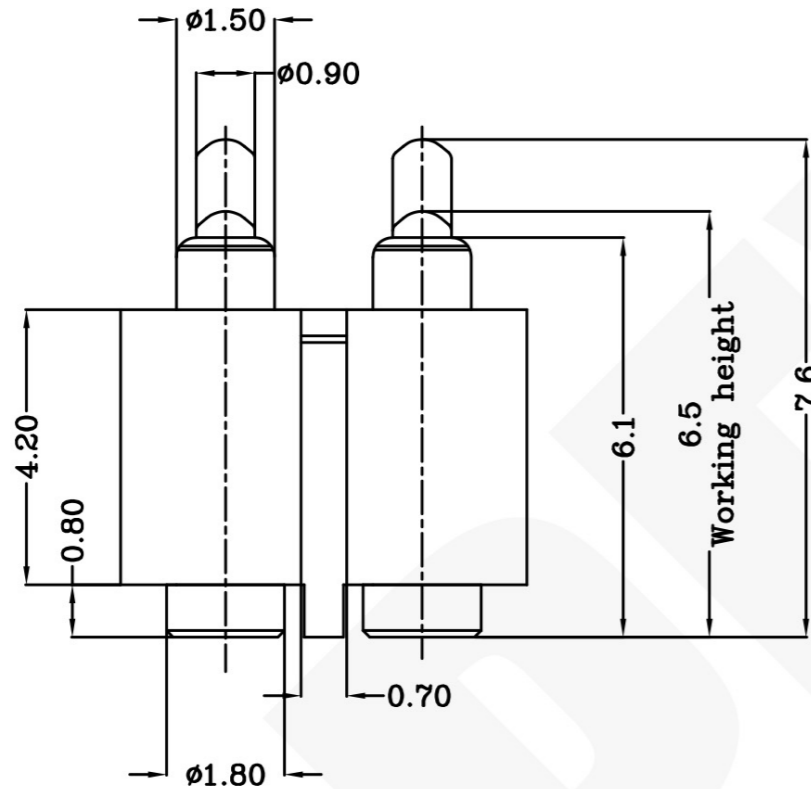
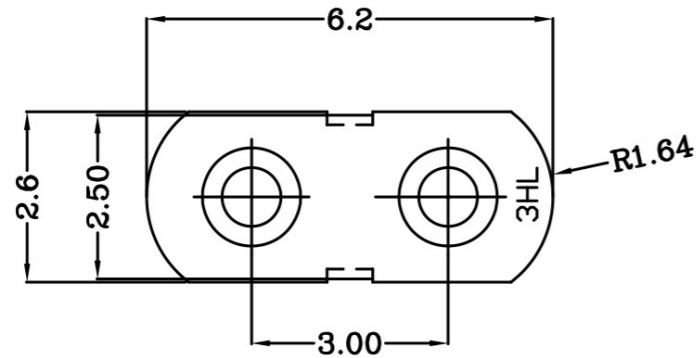

- Notes:
- 1 Material: PA 4.6 + 30% Glass fiber; Black (UL94V-0)
  - 2 General draft 1°.
  - 3 Part shall be free from flash, sharp edges, grease, sink mark, weld lines, porosities.
  - 4 Cavity Identification in this area.

LOC	-
DIST	-

LTR	REVISION RECORD	APVD	DATE
	3.60改为3.70		2007/06/22

DIMENSIONS IN MM  
TOLERANCES UNLESS  
OTHER SPECIFIED  
0 = ±  
0.0 = ±0.10  
0.00 = ±0.10  
0.000 = ±  
ANGLE: ±1°  
SURF TEXTURE: 3.2/  
REMOVE BURRS. BREAK  
SHARP EDGES R0.05 MAX  
DO NOT SCALE PRINT

MATL	1	HT TR	-	FIN	- ✓
DWN	Benny	APVD	Lansing	<b>PEXON</b>	
CHK	Andy	REL			
NAME POGO 2P PGC-1.5-7.6-R-2P-3.0PH					
SCALE	1:1	A4	DWG NO. 100023-2	SHEET 1 OF 1	REV C

100023-2
PART NUMBER

4

3

2

1

D  
C  
B  
A



**PEXON**

E-mail: [sale@pinconnector.com](mailto:sale@pinconnector.com)

WhatsApp: +86-13361867201

[www.pinconnector.com](http://www.pinconnector.com)