

THIS INFORMATION IS CONFIDENTIAL AND IS DISCLOSED TO YOU ON CONDITION THAT NO FURTHER DISCLOSURE IS MADE BY YOU TO OTHER THAN PEXON PERSONNEL WITHOUT WRITTEN AUTHORIZATION FROM PEXON LTD.

DWG NO.
C-100261

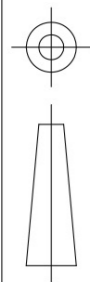

USED ON

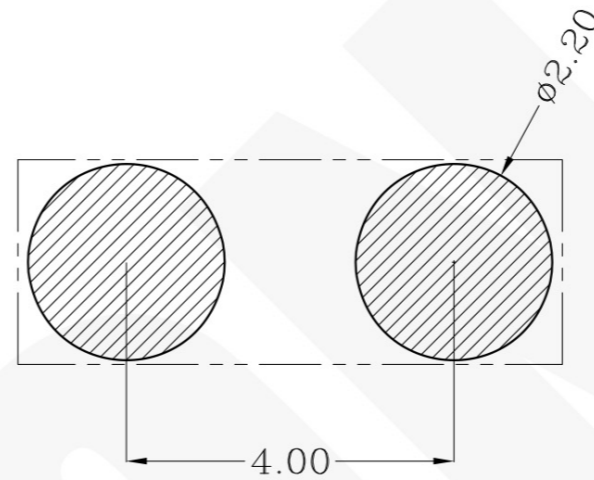
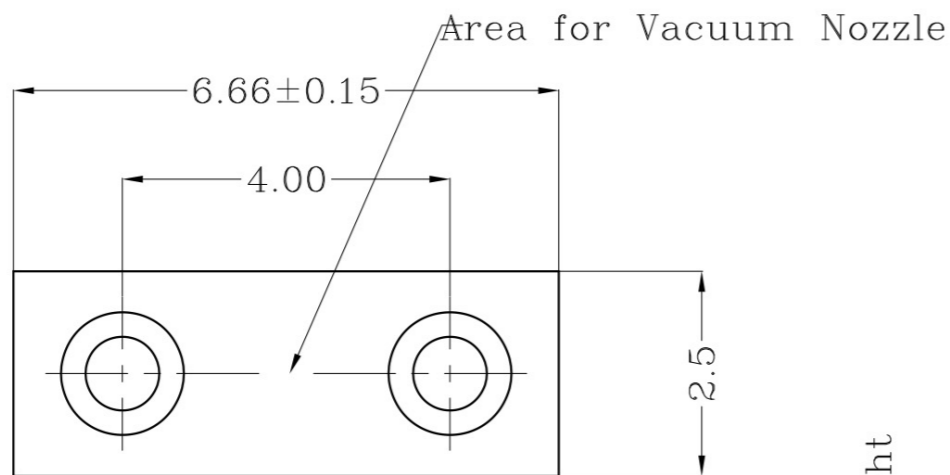

Recommended PCB Layout

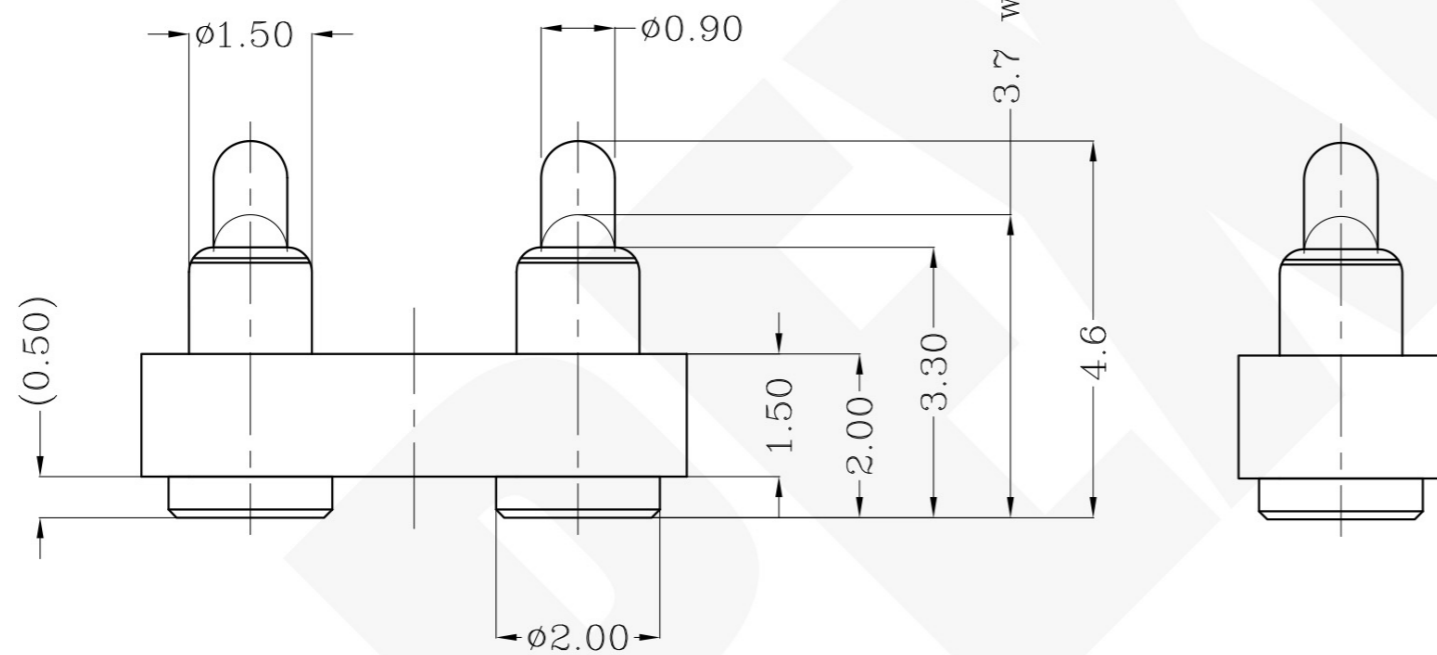
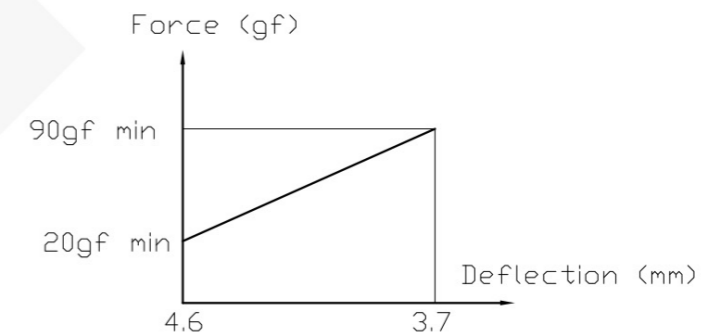

- Notes:
- Material, Housing: PA 4.6 (30% Glass Filled)
Color Black.
Contact: Brass
 - Mechanical demands:
Plating Plunger: 0.4um Au over 1.4um Ni
Plating Body: 0.1um Au over 1.4um Ni.

DIMENSIONS IN MM
TOLERANCES UNLESS
OTHER SPECIFIED
0 = ±-
0.0 = ±0.15
0.00 = ±0.10
0.000 = ±
ANGLE: ±1°
SURF TEXTURE: 3.2/
REMOVE BURRS, BREAK
SHARP EDGES R0.05 MAX
DO NOT SCALE PRINT

MATL	1	HT TR	-	FIN	- ✓
DWN	Qin	APVD		<h1>Pexon</h1>	
CHK		REL			
NAME BATTERY POGO CONNECTOR 2 POSITIONS PGC-1.5-4.6-R-2P-4.0PH					
SCALE	1:1	A4	DWG NO. C-100261	SHEET 1 OF 1	REV A

LOC	-
DIST	-

LTR	NEW	APVD	DATE
			2009/09/11

4

3

2

1

D

C

B

A



PEXON

E-mail: sale@pinconnector.com

WhatsApp: +86-13361867201

www.pinconnector.com