

THIS INFORMATION IS CONFIDENTIAL AND IS DISCLOSED TO YOU ON CONDITION THAT NO FURTHER DISCLOSURE IS MADE BY YOU TO OTHER THAN PEXON PERSONNEL WITHOUT WRITTEN AUTHORIZATION FROM PEXON LTD.

DWG NO.
C-100635

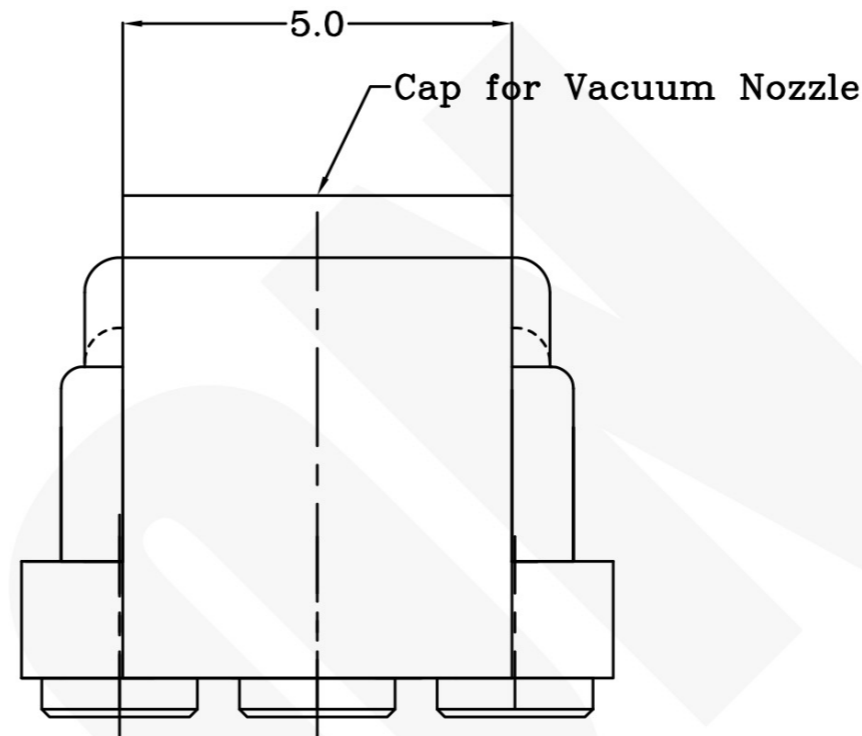

USED ON
-

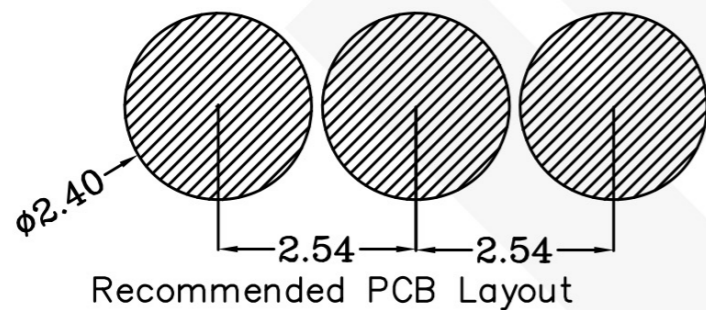
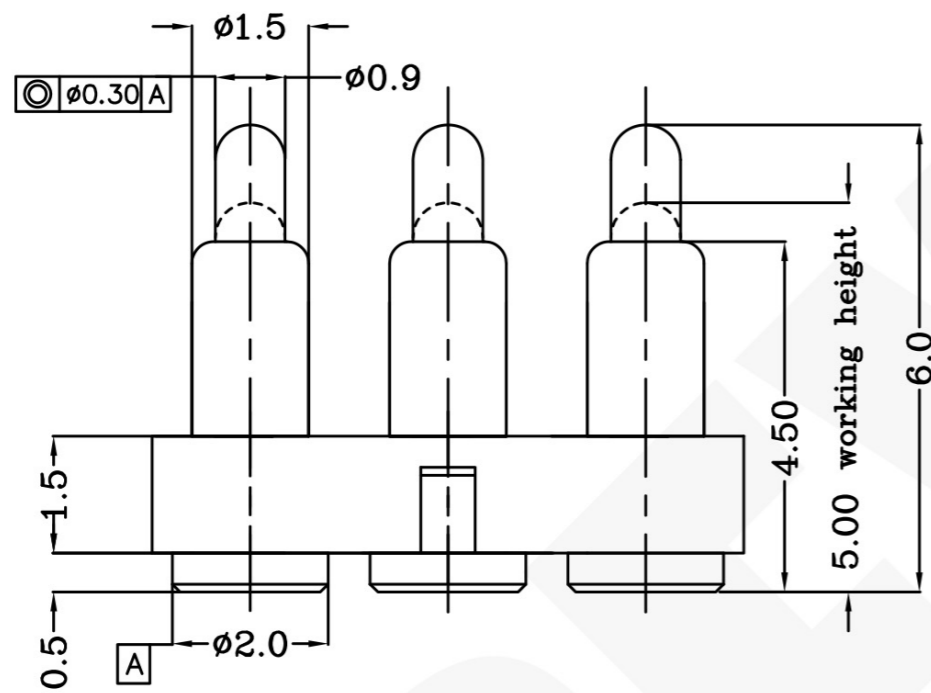
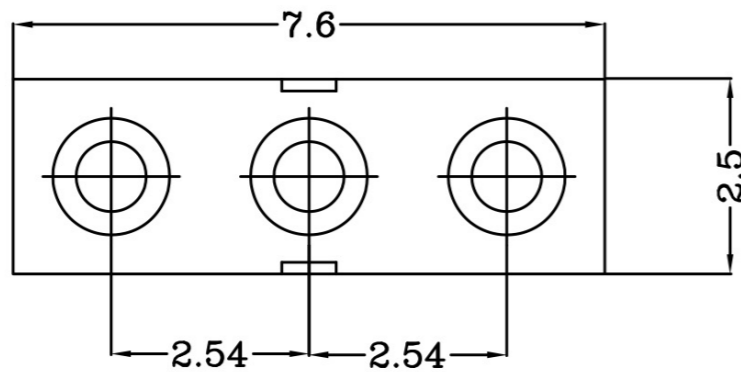

Notes:

- 1 Material(材质):
Housing: High temp.Plastic, UL94 V-0 Color Black.
Contact: Brass
Spring :Stainless steel wire
- 2 Plating:
1)Body: Min 0.1um Gold plating over min. 1.4um Nickel plating
(Body: 镀金0.1um Min 镍底1.4um Min)
2)Plunger: Min 0.4um Gold plating over min. 1.4um Nickel plating
(Plunger: 镀金0.4um Min 镍底1.4um Min)
- 3 Mechanical:
Total stroke(总行程): 1.40mm
Durability(寿命): 10,000 cycle min.
- 4 Electrical(电性能)
Contact resistance(接触阻抗): 30mOhm Max.
Voltage rating(额定电压): 36V DC Max
Current rating(额定电流): 2.0A

100635-3

PART NUMBER

DIMENSIONS IN MM
TOLERANCES UNLESS
OTHER SPECIFIED
0 = ±-
0.0 = ±0.15
0.00 = ±0.10
0.000 = ±
ANGLE: ±1°
SURF TEXTURE: 3.2/
REMOVE BURRS. BREAK
SHARP EDGES R0.05 MAX
DO NOT SCALE PRINT

MATL	△1	HT TR	-	FIN	- ✓
DWN	QIN	CHK	APVD	REL	Pexon
NAME BATTERY POGO CONNECTOR 3 POSITIONS PGC-1.5-6.0-R-3P-2.54PH					
SCALE	1:1	A4	DWG NO.	C-100635	SHEET 1 OF 1 REV A

LDC	-
DIST	-

	增标同轴度		10/09/09
	NEW		2010/09/08
LTR	REVISION RECORD	APVD	DATE

4

3

2

1

D

C

B

A



PEXON

E-mail: sale@pinconnector.com

WhatsApp: +86-13361867201

www.pinconnector.com