

THIS INFORMATION IS CONFIDENTIAL AND IS DISCLOSED TO YOU ON CONDITION THAT NO FURTHER DISCLOSURE IS MADE BY YOU TO OTHER THAN PEXON PERSONNEL WITHOUT WRITTEN AUTHORIZATION FROM PEXON LTD.

DWN No.: C-101515

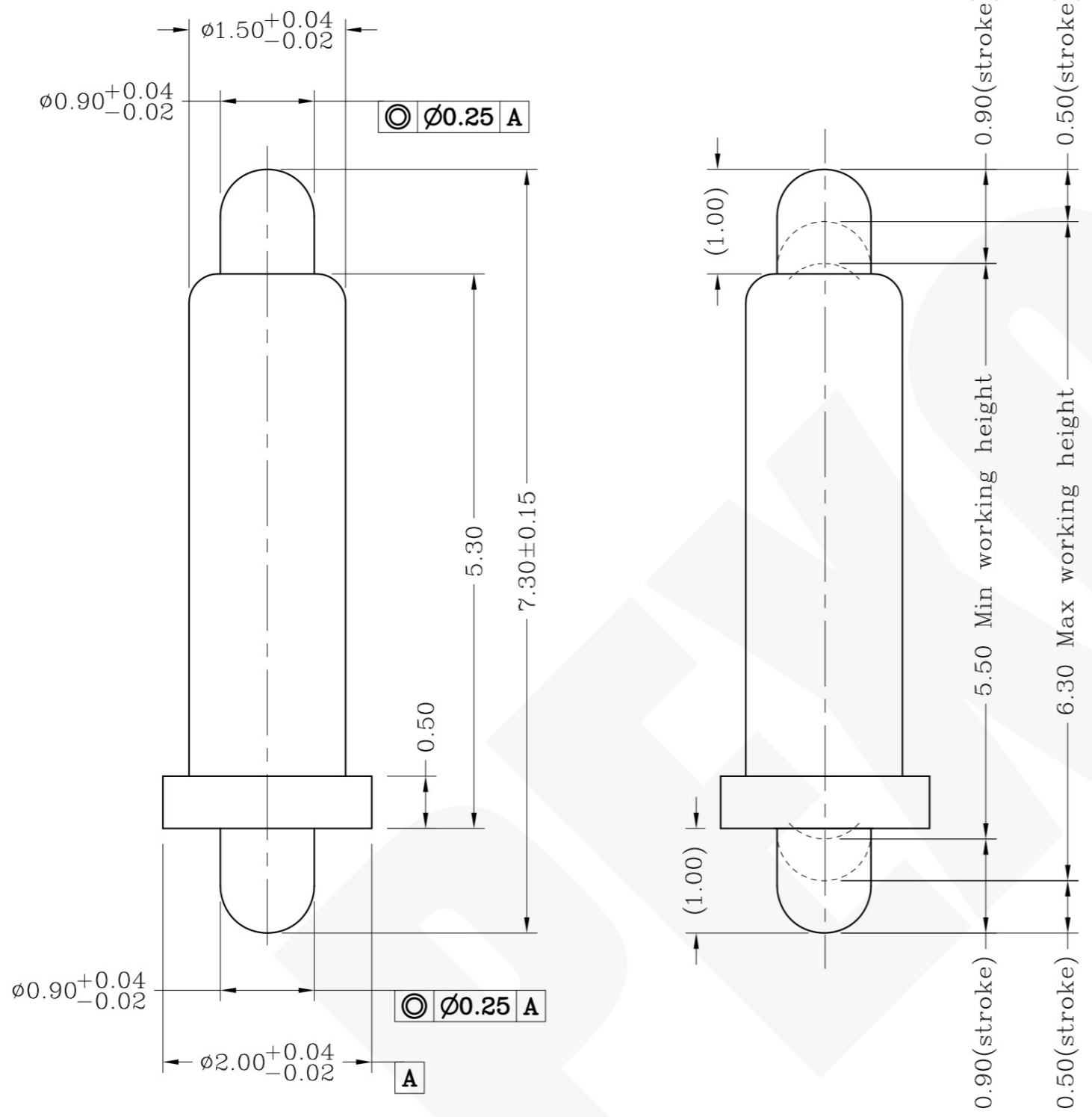

| Item | Part name | Q'ty/Ea' | Material | Finish |
|------|-----------|----------|----------------------|--------------------|
| 1 | Body | 1 | Leaded Brass | Au plating over Ni |
| 2 | Plunger | 2 | Leaded Brass | Au plating over Ni |
| 3 | Spring | 1 | Stainless steel wire | _____ |
| 4 | | | | |
| 5 | | | | |

| | | |
|--------------------|------------|---------------|
| Max working height | 6.30mm | 80gf min<2.1> |
| Min working height | 5.50mm | 170±35gf |
| Durability | 10000cycle | |

Notes:
 1 Dimensions shall be interpreted per ASME Y14.5M.
 2 Mechanical performance(See the table 1)
 <2.1>The force is the average of forces obtained when plunger goes downwards and upwards.
 <2.2>Warning: Working height are not permitted to be less than Min working height.
 3 Electrical performance
 Resistance: 30mOhm max
 Current rating: 2.0A
 4 RoHS compliant.
 5 Customer P/N: C106

101515-1
PART NUMBER

| Rev. | Revision record. | Date. |
|------|------------------|------------|
| 3 | UPDATE | 2013/11/14 |
| 2 | UPDATE | 2013/11/13 |
| 1 | NEW | 2011/08/02 |

| | | | | |
|---|---------|-----------------------|----------|--------------|
| Top-Link Electronics Ltd. | | Type Customer drawing | Unit mm | Weight |
| TOLERANCES UNLESS OTHER SPECIFIED 0. = ± - 0.0 = ± 0.15 0.00 = ± 0.10 0.000 = ± - Angle: ± SURF TEXTURE: REMOVE BURRS. BREAK SHARP EDGES R0.05 MAX.DO NOT SCALE PRINT. | | DWN: Cai wanlu | APVD: | PEXON |
| | | CHK: | REL: | |
| Name POGO PIN | | | | |
| Scale 1:1 | Size A4 | DWG No. C-101515 | Page 1/1 | Rev. 3 |

DIST

4 3 2 1



PEXON

E-mail: sale@pinconnector.com

WhatsApp: +86-13361867201

www.pinconnector.com