

THIS INFORMATION IS CONFIDENTIAL AND IS DISCLOSED TO YOU ON CONDITION THAT NO FURTHER DISCLOSURE IS MADE BY YOU TO OTHER THAN PEXON PERSONNEL WITHOUT WRITTEN AUTHORIZATION FROM PEXON LTD.

DWN No.: C-100232

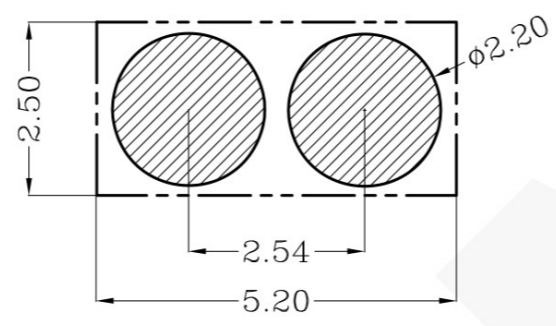

Recommended PCB Layout

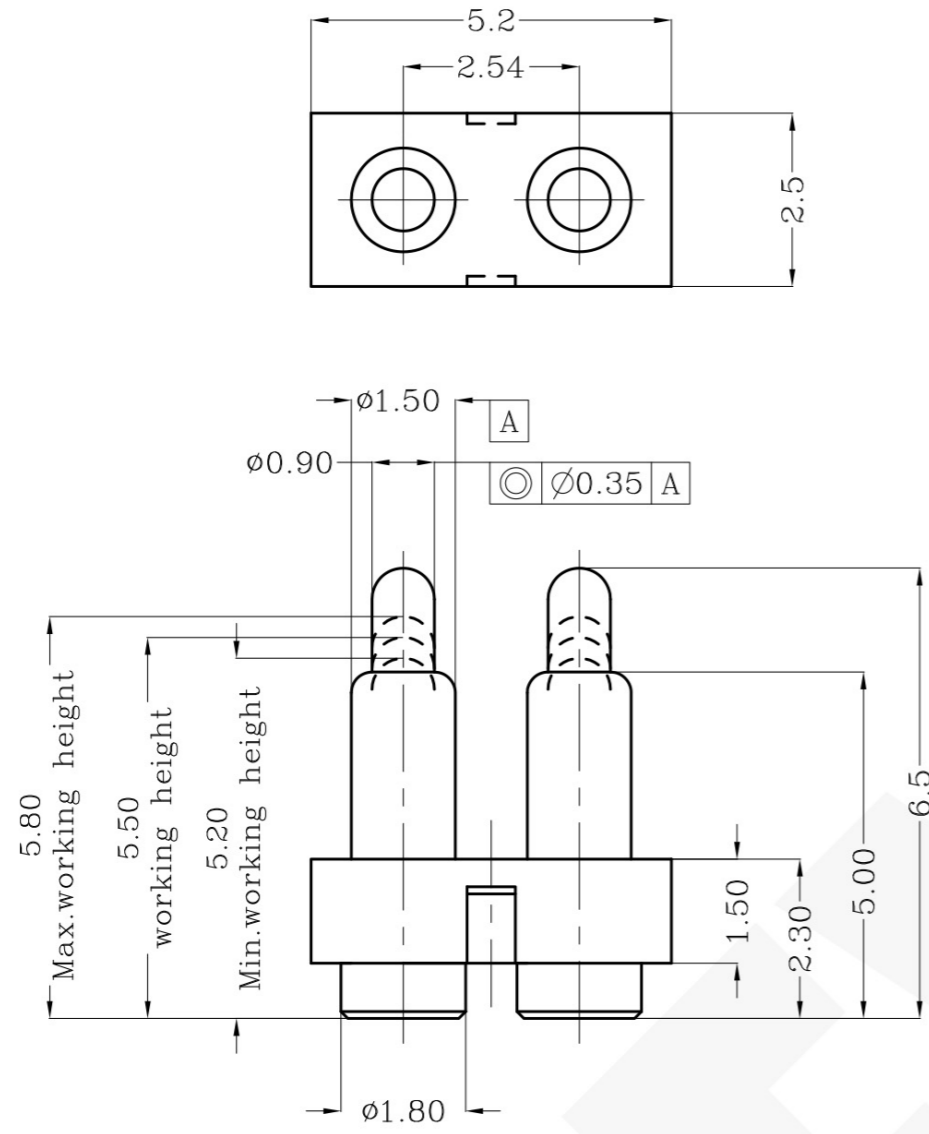
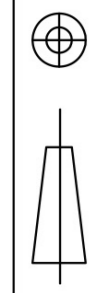
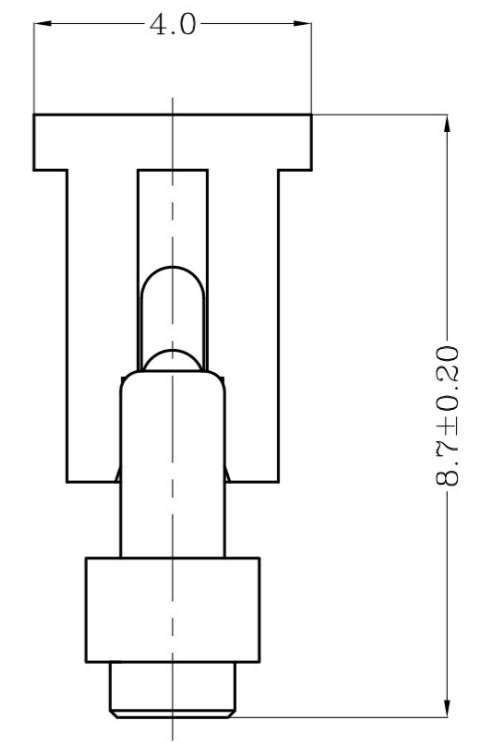
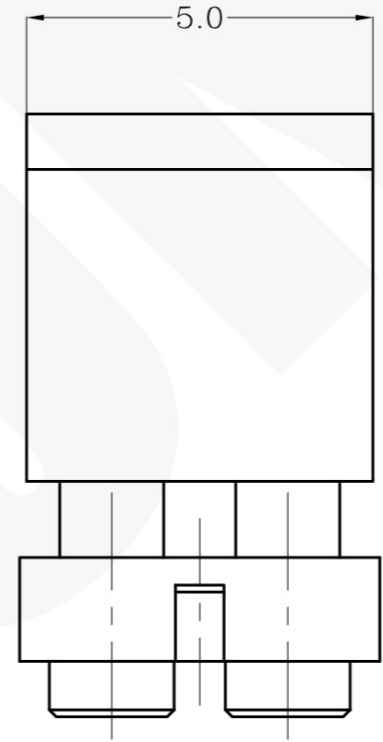

| Item | Part name | Q'ty/Ea' | Material | Finish |
|------|-----------|----------|---|----------------------------------|
| 1 | HSG | 1 | High temp.Plastic UL94 V-0 Color Black | _____ |
| 2 | Body | 2 | Leaded Brass | Gold plating over Nickel plating |
| 3 | Plunger | 2 | Leaded Brass | Gold plating over Nickel plating |
| 4 | Spring | 2 | Stainless steel wire | _____ |
| 5 | CAP | 1 | High temp.Plastic UL94 V-0 Color Black | _____ |

- Notes:
- Dimensions shall be interpreted per ASME Y14.5M.
 - Mechanical performance(See the table 1)
<2.1>The force is the average of forces obtained when plunger goes downwards and upwards.
<2.2>Warning: Working height are not permitted to be less than Min working height.
 - Electrical performance
Resistance: 30mOhm Max.
Current rating: 2.0A
 - Packaging specification conforms to EIA 481
 - RoHS compliant.

| | | |
|----------------|------------|----------------|
| working height | 5.50mm | 90gf Min <2.1> |
| Durability | 10000cycle | |

100232-2
PART NUMBER

| | | | | | | |
|---|--|-------|------------------|-------|----|--------------------|
| Top-Link Electronics Ltd. | | Type | Customer drawing | Unit | mm | Weight |
| TOLERANCES UNLESS OTHER SPECIFIED | | DWN: | Qin Zuozhong | APVD: | | PEXON |
| 0. = ± - | | CHK: | | REL: | | |
| 0.0 = ± 0.15 | | Name | | | | Pogo pin connector |
| 0.00 = ± 0.10 | | Scale | 1:1 | Size | A4 | DWG No. |
| 0.000 = ± - | | | | | | C-100232 |
| Angle: ±1° | | | | | | Page |
| SURF TEXTURE: REMOVE BURRS. | | | | | | 1/1 |
| BREAK SHARP EDGES R0.05 MAX.DO NOT SCALE PRINT. | | | | | | Rev. |
| | | | | | | A1 |

| Rev. | Revision record. | Date. |
|------|------------------|------------|
| | NEW | 2007/11/29 |
| 3 | | |

DIST

DIST



PEXON

E-mail: sale@pinconnector.com

WhatsApp: +86-13361867201

www.pinconnector.com