

DWN No.: C-100469

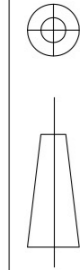

THIS INFORMATION IS CONFIDENTIAL AND IS DISCLOSED TO YOU ON CONDITION THAT NO FURTHER DISCLOSURE IS MADE BY YOU TO OTHER THAN PEXON PERSONNEL WITHOUT WRITTEN AUTHORIZATION FROM PEXON LTD.

DIST  
---  
DIST  
---

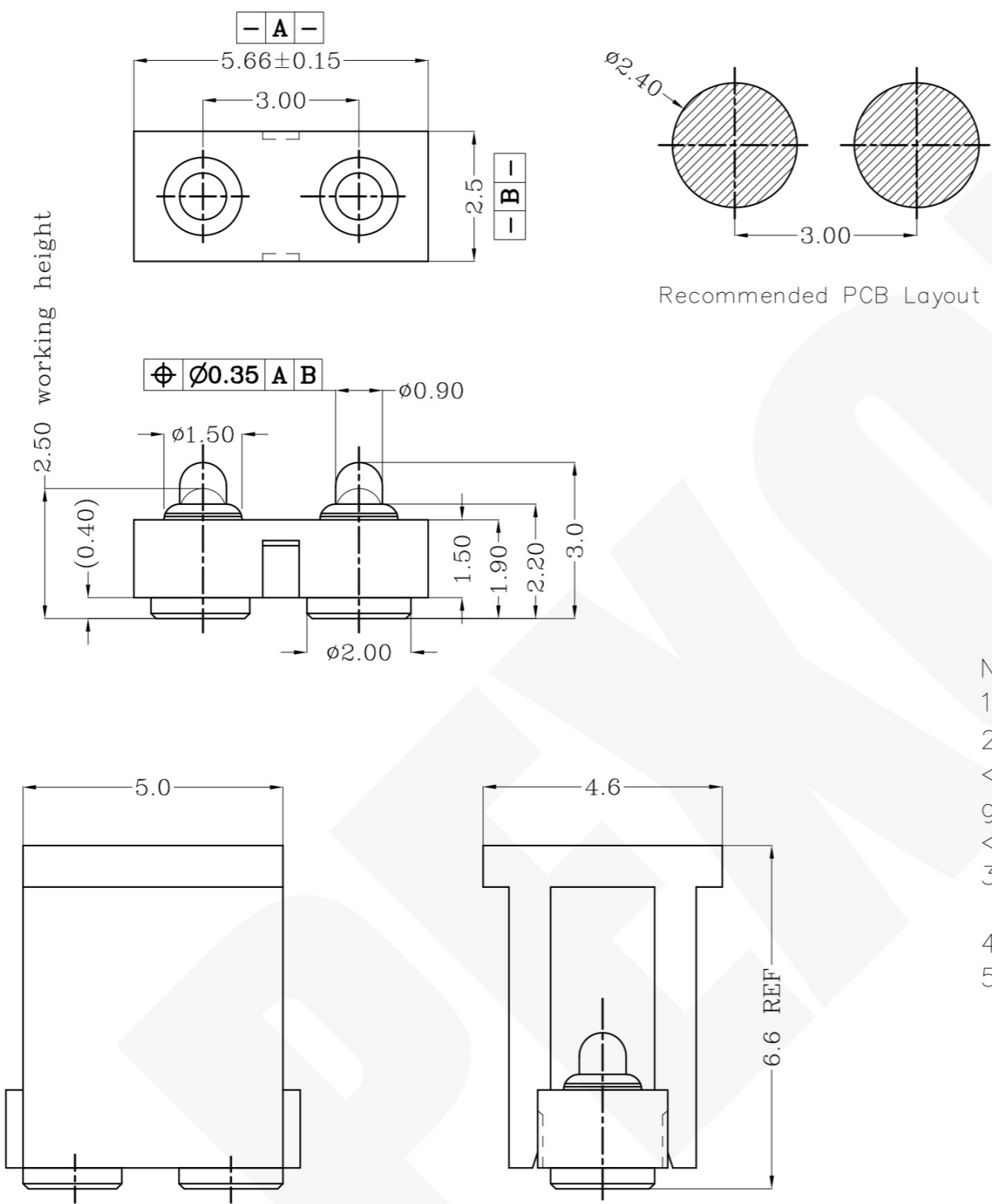

| Item | Part name | Q'ty/Ea' | Material                                  | Finish                    |
|------|-----------|----------|---|---------------------------|
| 1    | HSG       | 1        | High temp.Plastic<br>UL94 V-0 Color Black | _____                     |
| 2    | Body      | 2        | Leaded Brass                              | Au 0.1um plating Ni 1.4um |
| 3    | Plunger   | 2        | Leaded Brass                              | Au 0.4um plating Ni 1.4um |
| 4    | Spring    | 2        | Stainless steel wire                      | _____                     |
| 5    | CAP       | 1        | High temp.Plastic<br>UL94 V-0 Color Black | _____                     |

| Table 1 Mechanical performance |            |                |
|--------------------------------|------------|----------------|
| working height                 | 2.50mm     | 90gf min <2.1> |
| Durability                     | 10000cycle |                |

Notes:  
 1 Dimensions shall be interpreted per ASME Y14.5M.  
 2 Mechanical performance(See the table 1)  
 <2.1>The force is the average of forces obtained when plunger goes downwards and upwards.  
 <2.2>Total stroke:0.7mm  
 3 Electrical performance  
 Resistance: 30mOhm Max.Current rating: 2.0A  
 4 Packaging Spec.Comformance to EIA 481  
 5 RoHS compliant.

100469-2  
PART NUMBER

| Rev. | Revision record. | Date.      |
|------|------------------|------------|
| 3    | NEW              | 2011/07/25 |

|   |         |                       |          |              |
|---|---------|-----------------------|----------|--------------|
| Top-Link Electronics Ltd.   |         | Type Customer drawing | Unit mm  | Weight       |
| TOLERANCES UNLESS OTHER SPECIFIED<br>0. = ± -<br>0.0 = ± 0.15<br>0.00 = ± 0.10<br>0.000 = ± -<br>Angle: ±1°<br>SURF TEXTURE:<br>REMOVE BURRS.<br>BREAK SHARP EDGES<br>R0.05 MAX.DO NOT SCALE PRINT. |         | DWN: Qin Zuozhong     | APVD:    | <b>PEXON</b> |
|   |         | CHK:                  | REL:     |              |
| Name Customer drawing   |         |                       |          |              |
| Scale 1:1   | Size A4 | DWG No. C-100469      | Page 1/2 | Rev. A       |



**PEXON**

E-mail: [sale@pinconnector.com](mailto:sale@pinconnector.com)

WhatsApp: +86-13361867201

[www.pinconnector.com](http://www.pinconnector.com)