

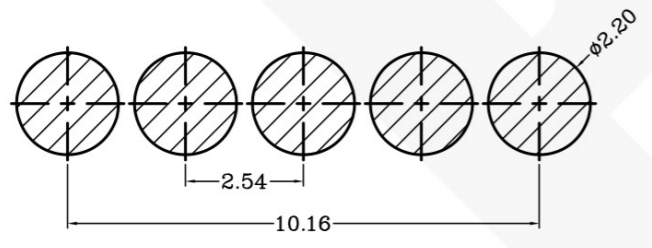

THIS INFORMATION IS CONFIDENTIAL AND IS DISCLOSED TO YOU ON CONDITION THAT NO FURTHER DISCLOSURE IS MADE BY YOU TO OTHER THAN PEXON PERSONNEL WITHOUT WRITTEN AUTHORIZATION FROM PEXON LTD.

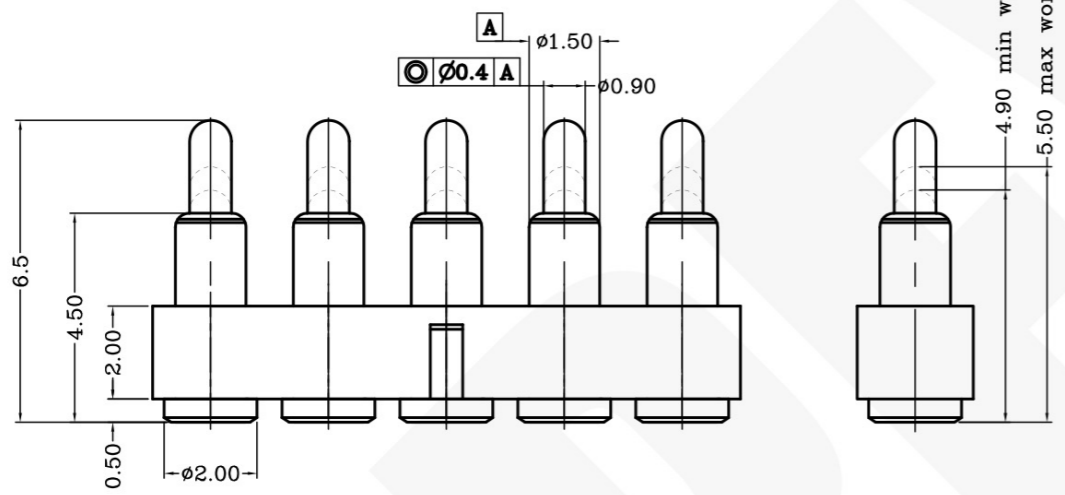
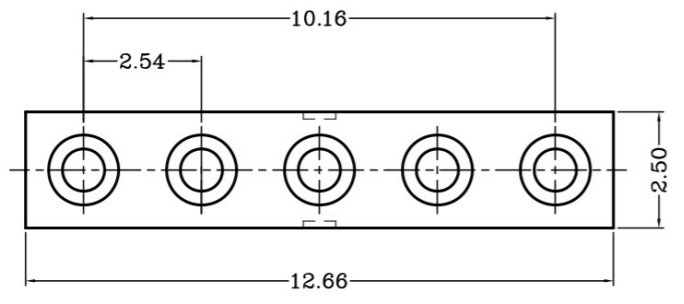
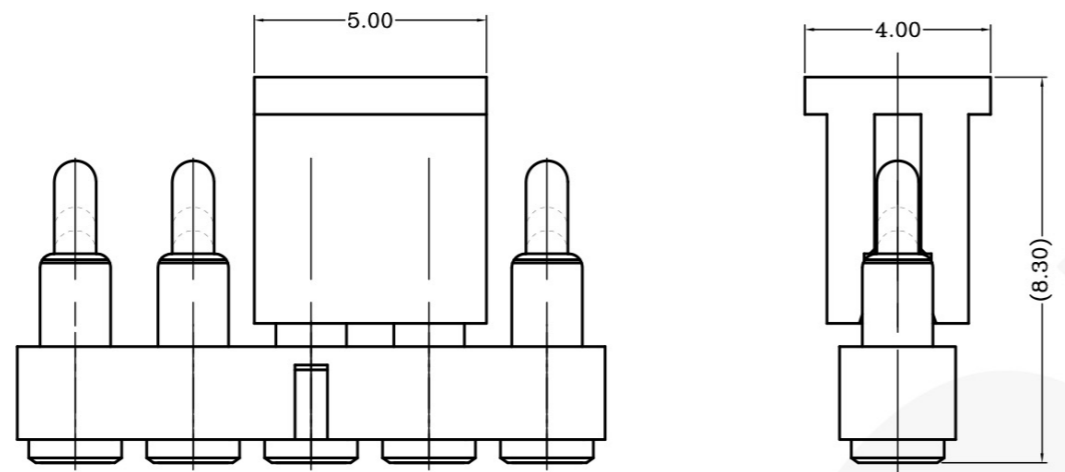

Recommended PCB Layout

Item	Part name	Q'ty/Ea'	Material	Finish
1	HSG	1	High temp.Plastic UL94 V-0 Halogen-free Color Black	_____
2	Body	5	C3604(黄铜C3604)	Au plating 0.1um min Ni plating 1.4um min
3	Plunger	5	C3604(黄铜C3604)	Au plating 0.4um min Ni plating 1.4um min
4	Spring	5	SUS304(不锈钢SUS304)	_____
5	CAP	1	胶芯PA46	_____

Parameter	Value 1	Value 2
Max.working height (最大工作高度)	5.50mm	80gf min<2.1>
Min.working height (最小工作高度)	4.90mm	180gf max<2.1>
Durability(寿命)	10000cycle(10000次)	

- Notes:
- Dimensions shall be interpreted per ASME Y14.5M.
尺寸标准遵从ASME Y14.5M.
 - Mechanical performance(See the table 1) (机械性能见表1)
<2.1>The force is the average of forces obtained when plunger goes downwards and upwards.
<2.1>弹力大小为产品下压和回弹时的平均值
<2.2>Warning: Working height are not permitted to be less than Min working height.
<2.2>工作高度不得低于标示的最小工作高度
 - Electrical performance (电气性能)
Insulation Resistance: 1,000MOhm minimum(绝缘电阻:1000M欧以上)
Dielectric Withstand Voltage: 500VAC/minute(抗电压: 500VAC/minute)
Dynamic Resistance: 30mOhm Max.(between max and min working height)
工作范围内的动态电阻:最大30mOhm
Current rating: 2.5A(额定电流:2.5A)
 - Packaging specification conforms to EIA 481
包装规范符合EIA 481
 - Working temperature (工作环境)
Withstanding Higt Temperature: 270°C(耐温: 270°C)
Operational Temperature: -40°C~+85°C工作温度: -40°C~+85°C)
 - RoHS compliant.(产品符合RoHS标准)

10101051227
PART NUMBER

Top-Link Electronics Ltd.		Type Customer drawing	Unit mm	Weight
TOLERANCES UNLESS OTHER SPECIFIED		DWN: Minos	APVD:	PEXON
0. = ± -		CHK:	REL:	
0.0 = ± 0.15		Name Pogo pin connector		
0.00 = ± 0.10		Scale 1:1	Size A4	DWG No. C-10101051227
0.000 = ± -		Page 1/1		
Angle: ±		Rev. 1		
SURF TEXTURE: REMOVE BURRS. BREAK SHARP EDGES R0.05 MAX.DO NOT SCALE PRINT.				

1	NEW	2017/07/17
Rev.	Revision record.	Date.
4	3	2

DIST

DIST



PEXON

E-mail: sale@pinconnector.com

WhatsApp: +86-13361867201

www.pinconnector.com