

THIS INFORMATION IS CONFIDENTIAL AND IS DISCLOSED TO YOU ON CONDITION THAT NO FURTHER DISCLOSURE IS MADE BY YOU TO OTHER THAN PEXON PERSONNEL WITHOUT WRITTEN AUTHORIZATION FROM PEXON LTD.

DWN No.: C-1001101

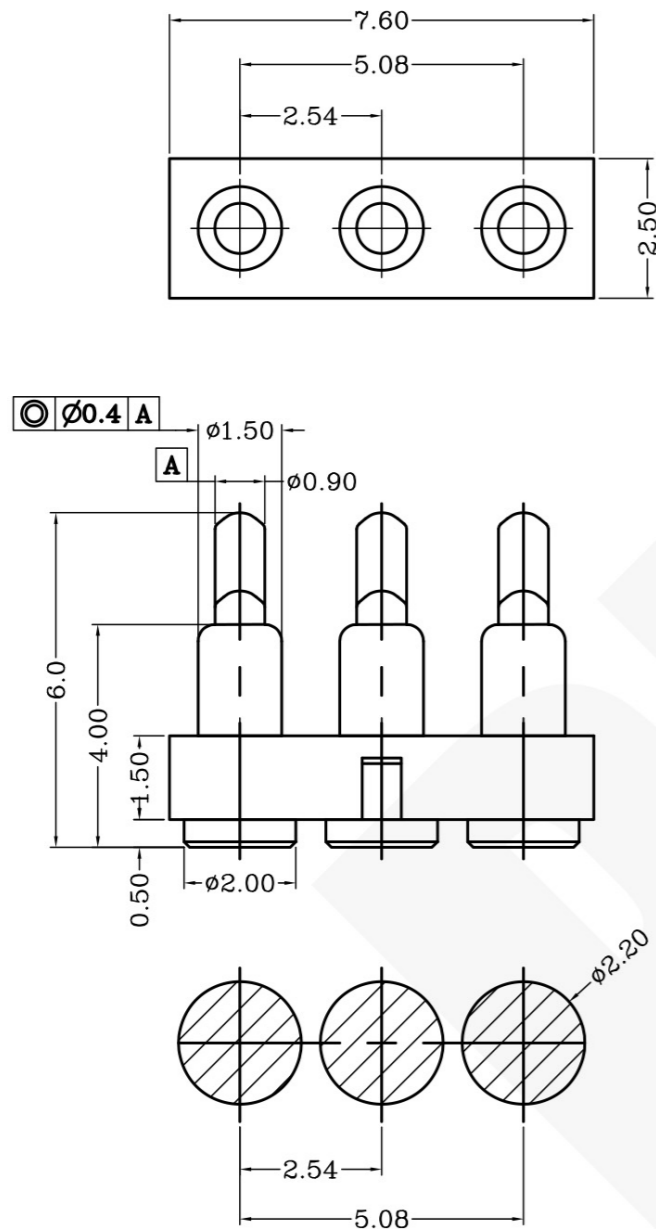

Recommended PCB Layout

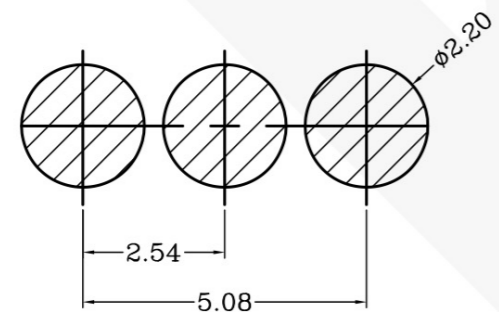
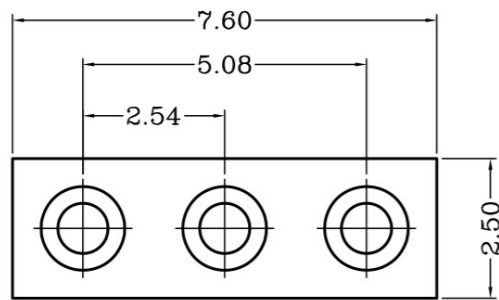
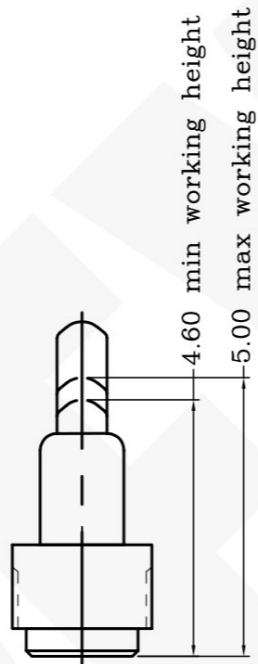
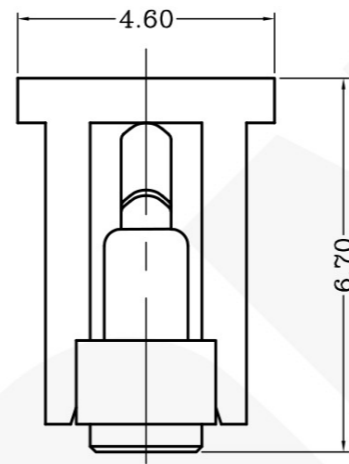
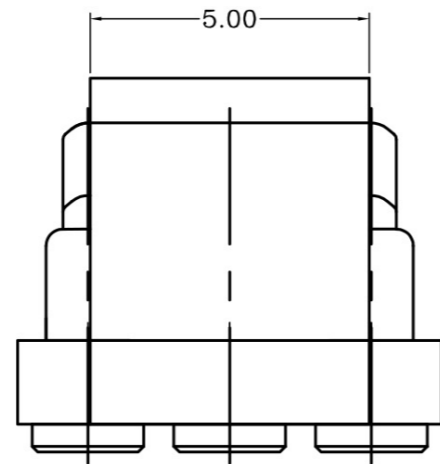

Item	Part name	Q'ty/Ea'	Material	Finish
1	HSG	1	胶芯PA46	—————
2	Body	3	C3604(黄铜C3604)	Au plating 0.1um min Ni plating 1.4um min
3	Plunger	3	C3604(黄铜C3604)	Au plating 0.4um min Ni plating 1.4um min
4	Spring	3	SUS304(不锈钢SUS304)	—————
5	CAP	1	胶芯PA46	—————

Parameter	Value	Notes
max working height (最大工作高度)	5.00mm	80gf min<2.1>
min working height (最小工作高度)	4.60mm	180gf max<2.1>
Durability(寿命)	10000cycle(10000次)	

Notes:

- Dimensions shall be interpreted per ASME Y14.5M.
尺寸标准遵从ASME Y14.5M.
- Mechanical performance(See the table 1) (机械性能见表1)
<2.1>The force is the average of forces obtained when plunger goes downwards and upwards.
<2.1>弹力大小为产品下压和回弹时的平均值
<2.2>Warning: Working height are not permitted to be less than Min working height.
<2.2>工作高度不得低于标示的最小工作高度
- Electrical performance (电气性能)
Insulation Resistance: 1,000MOhm minimum(绝缘电阻:1000M欧以上)
Dielectric Withstand Voltage: 500VAC/minute(抗击电压: 500VAC/minute)
Dynamic Resistance: 30mOhm Max.(between max and min working height)
工作范围内的动态电阻:最大30mOhm
Current rating: 2.5A(额定电流:2.5A)
- Packaging specification conforms to EIA 481
包装规范符合EIA 481
- Working temperature (工作环境)
Withstanding Higt Temperature: 270°C(耐温: 270°C)
Operational Temperature: -40°C~+85°C工作温度: -40°C~+85°C)
- RoHS compliant.(产品符合RoHS标准)

DIST

Rev.	Revision record.	Date.
2	change cap(更换盖子)	2014/01/15
1	NEW	2013/12/25

Top-Link Electronics Ltd.	Type Customer drawing	Unit mm	Weight
TOLERANCES UNLESS OTHER SPECIFIED 0. = ± - 0.0 = ± 0.15 0.00 = ± 0.10 0.000 = ± - Angle: ±1° SURF TEXTURE: REMOVE BURRS. BREAK SHARP EDGES R0.05 MAX.DO NOT SCALE PRINT.	DWN: Gui zhiguo CHK:	APVD: REL:	PEXON
Name Pogo pin connector			
Scale 1:1	Size A4	DWG No. C-1001101	Page 1/1 Rev. 2

1001101-3
PART NUMBER



PEXON

E-mail: sale@pinconnector.com

WhatsApp: +86-13361867201

www.pinconnector.com